

- L:
- CBL-U3.1CC-0.5m 500mm±10mm
  - CBL-U3.1CC-0.6m 600mm±10mm
  - CBL-U3.1CC-0.7m 700mm±10mm
  - CBL-U3.1CC-0.8m 800mm±10mm
  - CBL-U3.1CC-1m 1000mm±10mm
  - CBL-U3.1CC-2m 2000mm±20mm
  - CBL-U3.1CC-3m 3000mm±20mm

No	MATERIALS LIST:
1.	CABLE:UL2725 (30AWG*1PR+D+AM)x4C+32AWG*4C+32AWG*2C +26AWG*2C+AL+D+B OD:4.8mm PVC JACKET COLOR:BLACK
2.	CONNECTOR:USB 3.1 C/M, 22P, BLACK INSULATOR, SOLDER TYPE, NICKEL PLATED SHELL
3.	PVC MOLDED HOUSING, BLACK COLOR

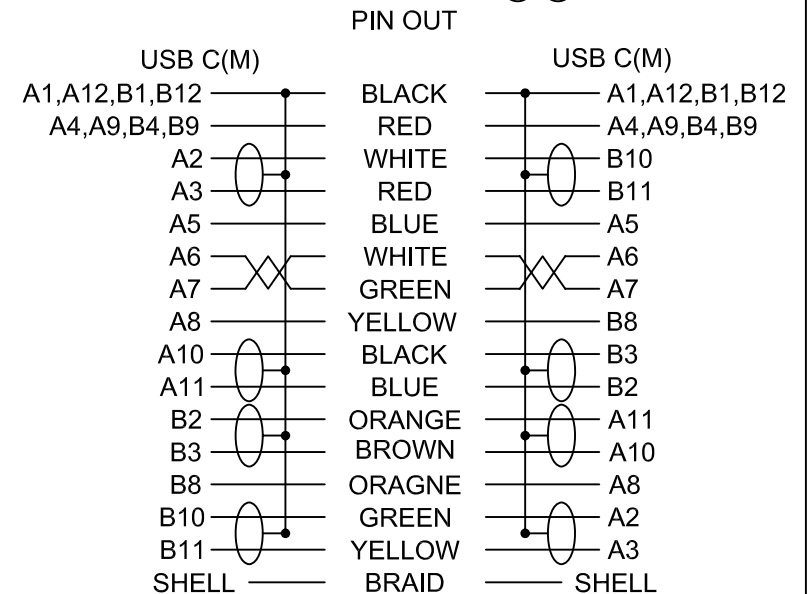

Jargy part no.	Client part no.	Approved	SCALE	UNIT
CBL-U3.1CC-Xm			1 : 1	mm
Drawing Name		Drawn	Date	REV.
USB 3.1 C to C Cable M/M		<i>Kevin Hsu</i>	2015/08/06	1.0